

MAXIM

MAX1906 Evaluation Kit

General Description

The MAX1906 evaluation kit (EV kit) is a complete, fully assembled and tested circuit board that is used to evaluate the MAX1906 lithium-ion (Li+) battery-pack protector. The MAX1906 EV kit protects the battery pack by blowing an on-board fuse when any individual cell in the battery pack exceeds the overvoltage protection threshold. The MAX1906 EV kit is designed to evaluate the MAX1906X 4-cell Li+ battery-pack protector. The EV kit can also be used to evaluate the MAX1906S 2-cell and the MAX1906V 3-cell Li+ battery-pack protectors. See the *Selector Guide* to request samples of the other ICs.

Warning: The MAX1906 EV kit is designed to work with Li+ batteries under potentially dangerous conditions. Exercise extreme caution when performing overcharge tests on live Li+ cells. Users who power up this EV kit or power the sources connected to it must be careful to follow safety procedures appropriate to working with Li+ batteries.

Under severe fault or failure conditions, this EV kit may dissipate large amounts of power, which could result in the mechanical ejection of a component or of component debris at high velocity. Operate this kit with care to avoid possible personal injury.

Features

- ◆ Overvoltage Protection
- ◆ On-Board Fuse
- ◆ Test Mode for Functional Verification
- ◆ Evaluates 2-, 3-, and 4-Cell Battery Protectors
- ◆ Fully Assembled and Tested

Ordering Information

PART	TEMP RANGE	IC PACKAGE
MAX1906EVKIT	0°C to +70°C	16 QFN, 5mm x 5mm

Selector Guide

PART	NO. OF CELLS / BATTERY PACK
MAX1906XEGE*	4
MAX1906VEGE	3
MAX1906SEGE	2

* Installed on the EV kit.

Component List

DESIGNATION	QTY	DESCRIPTION
C1-C4	4	0.1μF ±10%, 16V ceramic capacitors (0603) Taiyo Yuden EMK107BJ104KA or TDK C1608X7R1E104KT
F1	1	5A protection fuse Sony SFD-145B
JU1, JU2, JU3, JU6	4	2-pin headers
JU5	1	3-pin header
N1	1	30V, 5.2A N-channel FET (6-pin SuperSOT™) Fairchild FDC633N

DESIGNATION	QTY	DESCRIPTION
R1	1	10Ω ±5% resistor (0603)
R2, R3, R4	3	1kΩ ±5% resistors (0603)
R5	1	560Ω ±5% resistor (2512)
R6	1	100kΩ ±5% resistor (0603)
R7	0	Not installed, resistor (2512)
U1	1	MAX1906XEGE, 16-pin QFN
None	4	Shunts (JU1, JU2, JU3, JU5)
None	1	MAX1906 PC board
None	1	MAX1906 data sheet
None	1	MAX1906EVKIT data sheet

Component Suppliers

SUPPLIER	PHONE	FAX	WEBSITE
Fairchild	888-522-5372	Local representative	www.fairchildsemi.com
Sony	81-3-3279-0448	81-3-5255-8448	www.sccj.co.jp/html_e/
Taiyo Yuden	800-348-2496	847-925-0899	www.t-yuden.com
TDK	847-803-6100	847-390-4405	www.component.tdk.com

Note: Please indicate that you are using the MAX1906 when contacting the manufacturers.

SuperSOT is a trademark of Fairchild Semiconductor.

MAXIM

Maxim Integrated Products 1

For pricing, delivery, and ordering information, please contact Maxim/Dallas Direct! at 1-888-629-4642, or visit Maxim's website at www.maxim-ic.com.

Evaluates: MAX1906X/MAX1906V/MAX1906S

MAX1906 Evaluation Kit

Quick Start

The MAX1906 EV kit is a fully assembled and tested surface-mount board. Follow the steps below to verify board operation. **Do not turn on the battery charger until indicated:**

- 1) Verify that shunts are not installed on jumpers JU1, JU2, and JU3 (fuse protection is disabled).
- 2) Verify that shunts are installed on jumper JU6 and across pins 1 and 2 of jumper JU5.
- 3) Connect the positive terminals of three voltmeters to the OUT, DRV, and DISCON pads. Connect the negative terminal of the voltmeters to the PACK- pad.
- 4) Connect the positive terminal of a 3.3V source to the VI/O pad. Connect the negative terminal of the source to the PACK- pad.
- 5) Measure the voltage across the 4-cell battery pack.
- 6) Connect the 4-cell (series connected) Li+ battery pack across BN and BATT4+. **Observe the correct Li+ battery-pack polarity.**
 - a) Connect the negative terminal of the first cell to BN.
 - b) Connect the positive terminal of the first cell to BATT1+.
 - c) Connect the positive terminal of the second cell to BATT2+.
 - d) Connect the positive terminal of the third cell to BATT3+.
 - e) Connect the positive terminal of the fourth cell to BATT4+.

For test purposes, the Li+ cells can be replaced by four floating power supplies

- 7) Verify that the voltage across OUT and PACK- is approximately the voltage measured in step 5.
- 8) Disable the battery charger.
- 9) Connect the positive terminal of the battery charger to PACK+. Connect the negative terminal of the battery charger to PACK-.
- 10) Enable the battery charger.
- 11) Force overcharge conditions and observe that OUT is pulled low and DRV is driven to approximately 5V.

Note: In this configuration, fuse protection is disabled and the EV kit does not provide overvoltage protection. The current that would destroy the fuse in an overcharge condition is limited and sunk through resistor R5. Charging must be manually monitored. Enable fuse protection (one time) by removing the shunt across JU6 and installing it on JU3.

Detailed Description

The MAX1906 EV kit is a complete, fully assembled and tested circuit board that is used to evaluate the MAX1906X Li+ battery-pack protector. The MAX1906X is designed to protect an Li+ battery pack, where 4 cells are connected in series. The EV kit protects against potentially hazardous conditions by disconnecting the battery pack from the battery charger. This is accomplished by blowing the protection fuse in the circuit when any individual cell in the pack exceeds the over-voltage protection threshold.

Inputs

The MAX1906 EV kit does not require an external power source for the EV kit to function. The EV kit uses the battery pack as the power source. Connect the Li+ battery pack across BATT4+ and BN pads and the battery charger across PACK+ and PACK- pads.

The battery-pack terminals and all intermediate cell connection points must be connected to their corresponding input pads on the EV kit:

- 1) Connect the negative terminal of the first cell to BN.
- 2) Connect the positive terminal of the first cell to BATT1+.
- 3) Connect the positive terminal of the second cell to BATT2+.
- 4) Connect the positive terminal of the third cell to BATT3+.
- 5) Connect the positive terminal of the fourth cell to BATT4+.

One-Time Fuse

The MAX1906 EV kit disconnects the battery charger from the battery pack by blowing fuse F1 with high current when overcharging is detected. The fuse can only be used once and must be replaced if it is opened by overcharge detection. However, for repeated EV kit evaluation, the fuse can be bypassed by configuring JU3 and JU6 to redirect the high current through power resistor R5. Remove the shunt across JU3 and install the shunt across JU6 to avoid destroying the fuse. R5 limits the maximum current drawn in a fault condition to 31mA. Monitor all charging conditions of the battery pack when JU3 is open (fuse is disabled).

MAX1906 Evaluation Kit

Evaluates: MAX1906X/MAX1906V/MAX1906S

Table 1. JU5 Settings

SHUNT POSITION	EV KIT FUNCTION
1 and 2	Current sink through OUT pin
2 and 3	Current sink through MOSFET N1

Current Sink

The MAX1906 EV kit sinks current during overcharge detection to blow the fuse. The EV kit sinks current in one of two ways: internally through the OUT pin, or externally through MOSFET N1 driven by the DRV pin. JU5 must be configured to choose the path for the current. See Table 1 for JU5 configuration.

Note: During battery-overcharge detection, DRV is always driven high to drive the external MOSFET N1.

Test Mode

The MAX1906 IC includes a special test mode that allows the chip to be tested in a fully assembled battery pack. Refer to the *Test Mode* section in the MAX1906 data sheet for test-mode setup instructions. Use the TEST pad to set the EV kit in test mode.

Output Signals

The MAX1906 EV kit drives outputs OUT, DRV, and DISCON high or low to warn the user if fault conditions are detected. Refer to the MAX1906 data sheet for the state of these outputs under different conditions.

Evaluating MAX1906V/S

The MAX1906 EV kit is designed to evaluate the MAX1906X Li+ battery-pack protector. The EV kit can also be used to evaluate the MAX1906S 2-cell and the MAX1906V 3-cell Li+ battery-pack protectors. Order samples of these battery protectors and replace the MAX1906X (U1) on the board with the desired part. To evaluate other parts, configure JU1 and JU2 to account for the reduced number of cells in the Li+ battery pack. See Table 3 for JU1 and JU2 configurations.

Table 2. JU1 and JU2

PART ON EV KIT	NO. OF CELLS / BATTERY PACK	SHUNT POSITION	
		JU1	JU2
MAX1906XEGE	4	None	None
MAX1906VEGE	3	Installed	None
MAX1906SEGE	2	Installed	Installed

MAX1906 Evaluation Kit

Evaluates: MAX1906X/MAX1906V/MAX1906S

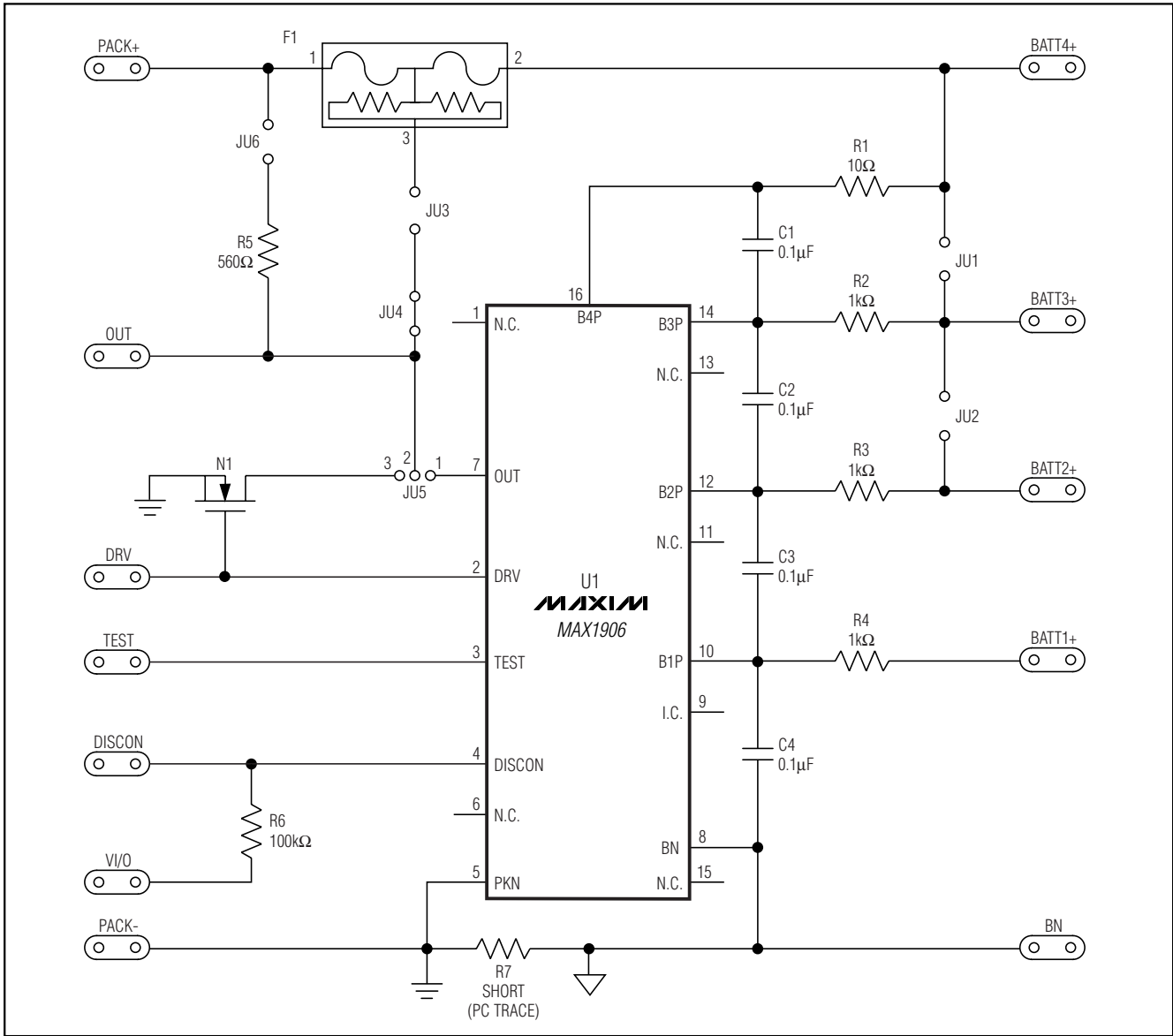

Figure 1. MAX1906 EV Kit Schematic

MAX1906 Evaluation Kit

Evaluates: MAX1906X/MAX1906V/MAX1906S

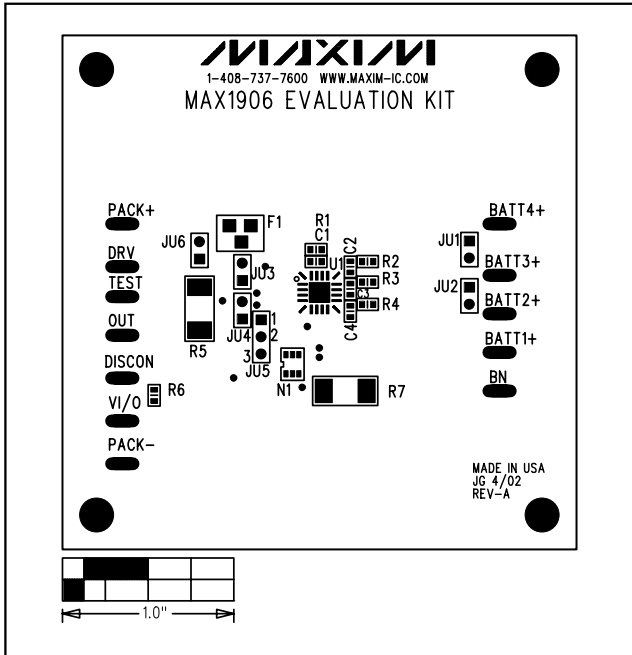

Figure 2. MAX1906 EV Kit Component Placement Guide—Component Side

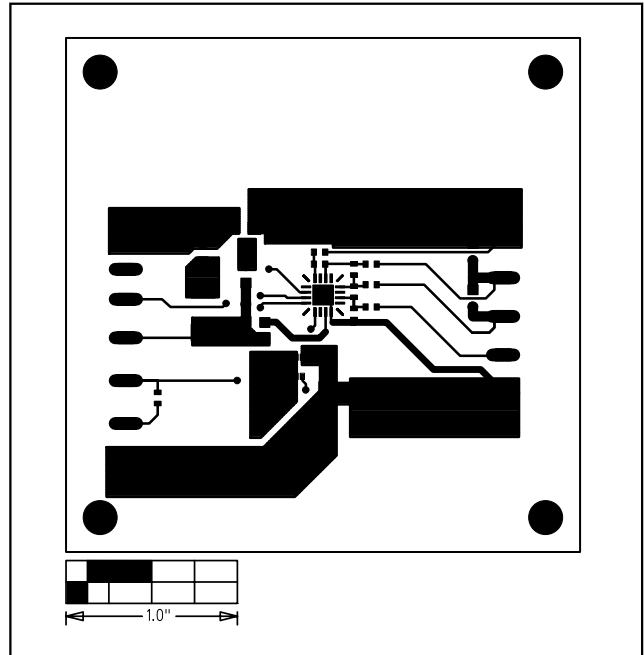

Figure 3. MAX1906 EV Kit PC Board Layout—Component Side

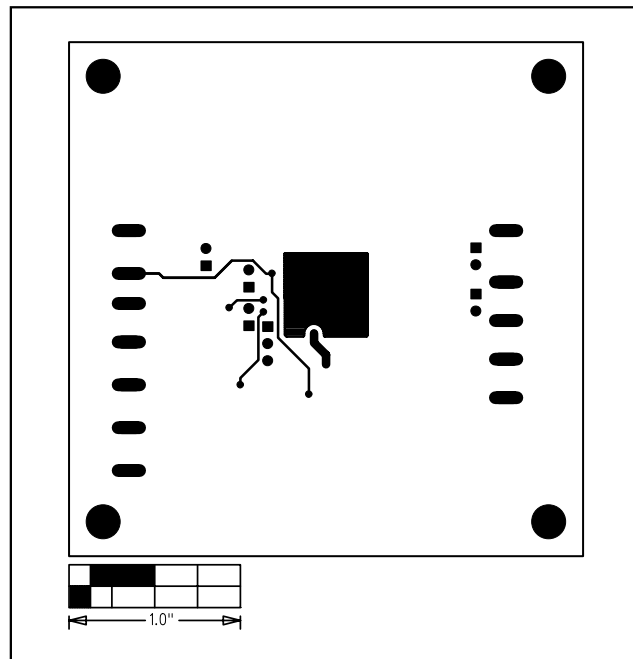

Figure 4. MAX1906 EV Kit PC Board Layout—Solder Side

Maxim cannot assume responsibility for use of any circuitry other than circuitry entirely embodied in a Maxim product. No circuit patent licenses are implied. Maxim reserves the right to change the circuitry and specifications without notice at any time.

Maxim Integrated Products, 120 San Gabriel Drive, Sunnyvale, CA 94086 408-737-7600 _____ 5